

## ARCHITECTURAL SPECIFICATIONS

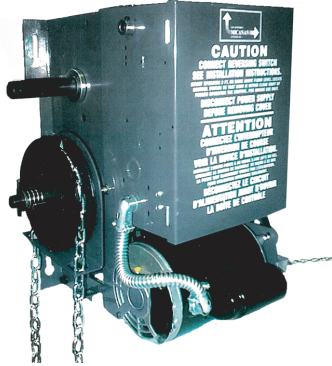

### COMMERCIAL / INDUSTRIAL BELT DRIVE JACKSHAFT WITH CHAIN HOIST

The PRO-H heavy-duty jackshaft operators are designed for commercial and industrial high lift, vertical lift, rolling doors and rolling grilles provided that doors are driven by a drive shaft. The PRO-H operators incorporates a chain hoist for manual operation of the door.

### STANDARD FEATURES

- Heavy duty reversing contactor c/w electrical interlock
- Continuous duty motor with overload protection
- Heavy duty 5L V-belt
- 3/4" ball bearing on pulley shaft
- 1" ball bearing on drive shaft
- 24V Fused Control Circuit
- C-2 wiring standard (Constant Pressure Close)
- Note: B-2 Wiring can be field set by moving 1 jumper wire. Safety equipment must be installed when B-2 wiring is used.
- External radio control terminal strip
- Three Button Control Station
- Fully adjustable rotary limit switches
- Powder metal limit cams
- Motor removable without affecting limit setting
- Adjustable friction clutch
- Mechanical Brake System
- Solenoid brake
- #50 roller chain drive & sprockets
- Chain Keeper
- Emergency chain hoist with electrical cutout switch for manual operation
- Left or right hand mounting (must specify at time of order)
- Baked on dark grey coat finish
- Approximate shipping weight 100 Lbs.
- Full feature logic control board (Optional)

### MOUNTING DETAIL

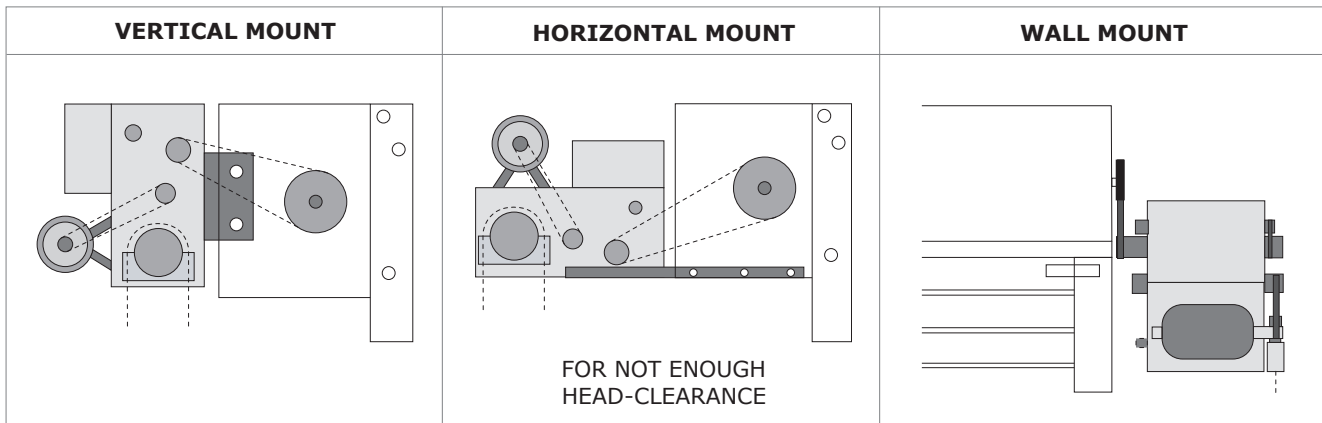



## OVERALL DIMENSIONS

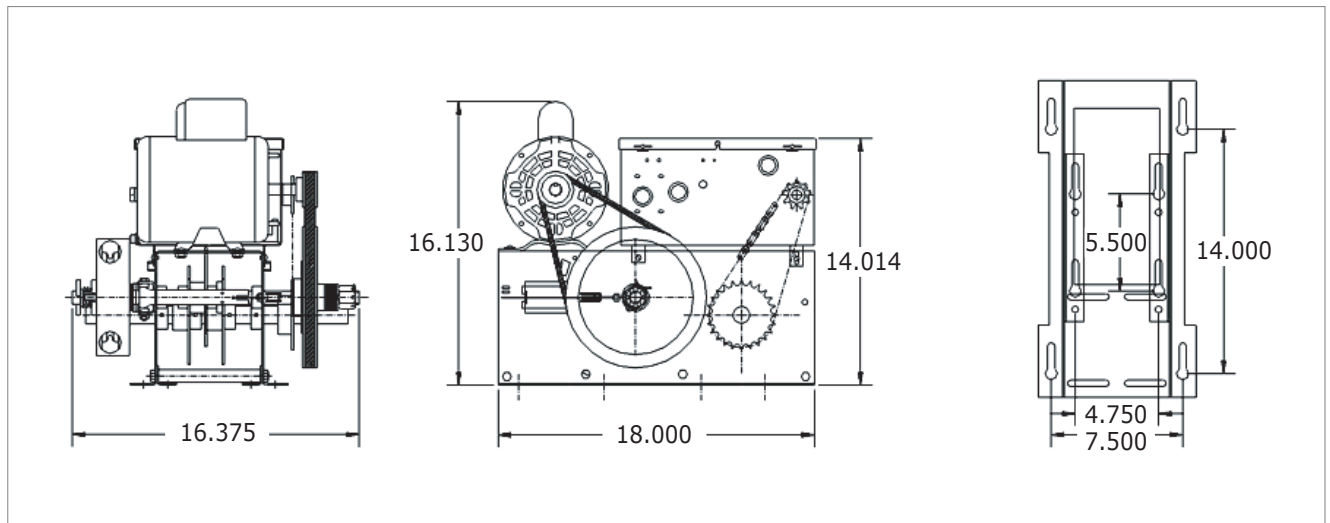

## HORSEPOWER SELECTION & MOTOR AMPERAGE GUIDE

PRO-H HORSEPOWER SELECTION GUIDE												
BELT DRIVE JACKSHAFT / HEAVY DUTY COMMERCIAL (25 CYCLES/HR)												
Steel	ROLLING DOORS					SECTIONAL DOORS						
	24GA	22GA	20GA	18GA	16GA		24GA	22GA	20GA	18GA	16GA	
Insulated Steel									24GA	22GA	20GA	16GA
Other	Aluminum Grilles	Aluminum Doors				Fiberglass		Aluminum Doors	Wood Doors			
HORSEPOWER	MAXIMUM SQUARE FEET					MAXIMUM SQUARE FEET						
1/3HP - 249W	320	275	225	200	160	310	295	285	260	215	175	125
1/2HP - 373W	400	350	300	280	250	400	365	350	320	280	250	200
3/4HP - 560W	560	500	425	380	325	560	520	500	450	365	325	275
1HP - 746W	625	575	500	445	400	625	605	575	500	445	400	310
MOTOR AMPERAGE GUIDE (Amps)												
VOLTAGE	1/3		1/2		3/4		1					
110V 1-phase	7.9		8.5		11.6		15.0					
220V 1-phase	3.9		4.2		6.0		7.5					
208V 3-phase			2.2		2.9		3.6					
230V 3-phase			2.1		2.8		3.5					
460V 3-phase			1.1		1.5		1.8					
575V 3-phase			1.0		1.2		1.5					